

The **Model 80 Gas Scrubber Valve** is used in Fuel Gas Scrubbers, and Air Eliminators. Installs through 2" pipe coupling or can be wholly contained by mounting by 1" nipple welded through cover. Can be used as a replacement for the Model IC-125 Scrubber Valve.

### Specifications

#### Body

60 KSI Tensile Steel

#### Connections

1" FPT x 2" MPT

#### Maximum Working Pressure

175 psi

#### Temperature Limits

-40°F to +250°F

#### Float

Aluminum

Float Specific Gravity

0.5

#### Seal

Buna N

### Ordering Information

#### Installation in Fuel Gas Scrubber

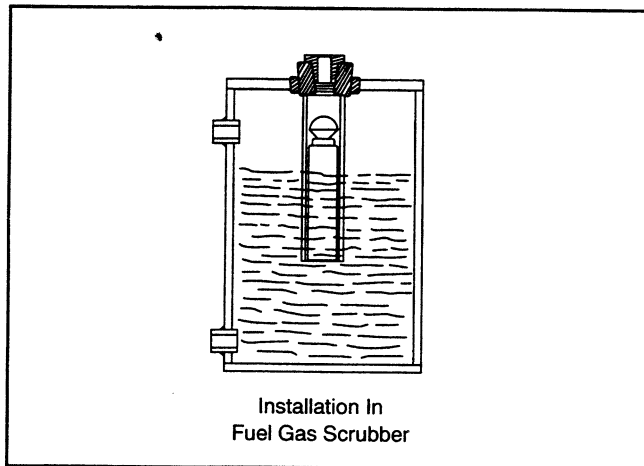

Model 80 Gas Scrubber Valve

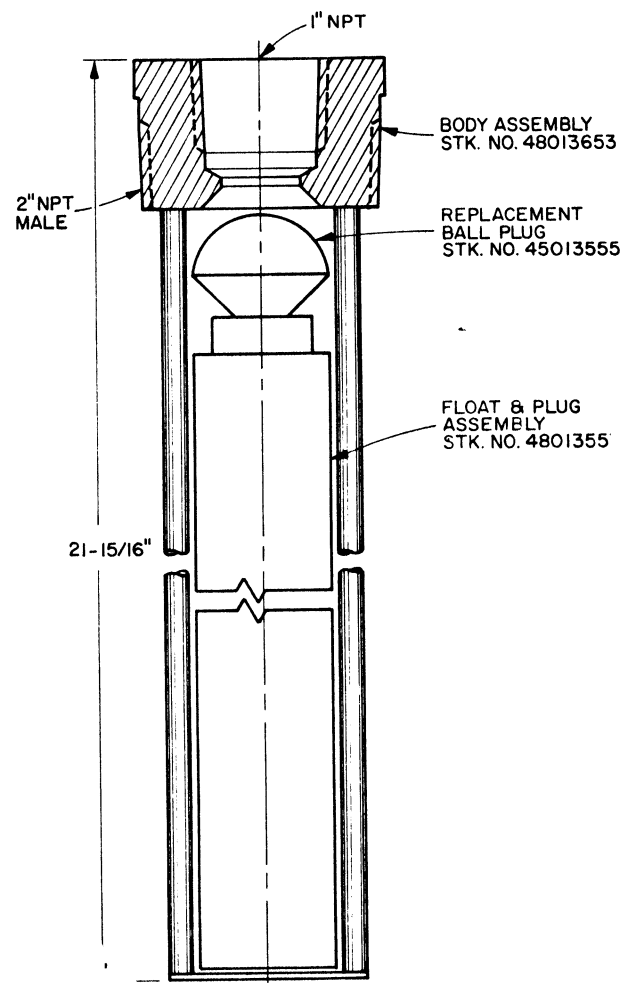



---

[www.fmcinvalco.com](http://www.fmcinvalco.com)

The specifications contained herein are subject to change without notice and any user of said specifications should verify from the manufacturer that the specifications are currently in effect. Otherwise, the manufacturer assumes no responsibility for the use of specifications which may have been changed and are no longer in effect.

---

**FMC INVALCO** Fluid Control Stephenville, TX 76401, Phone: 254/968-2181, FAX: 254/968-5709, Toll Free: 800/468-2526

Printed in U.S.A. © 6/04 FMC INVALCO All rights reserved. Issue/Rev. 0.2 (6/04)